

PRODUCT NUMBER
SEE SHEET 3

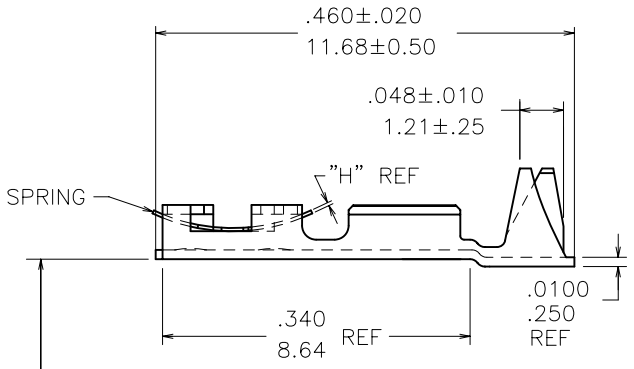
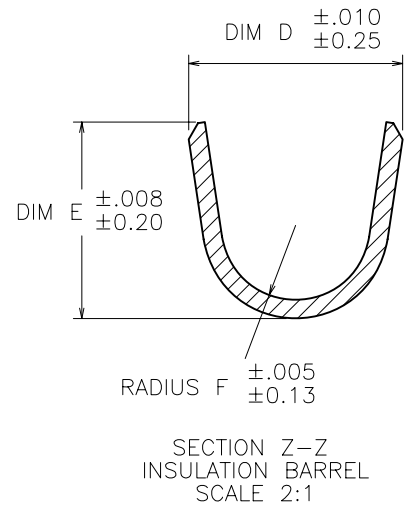
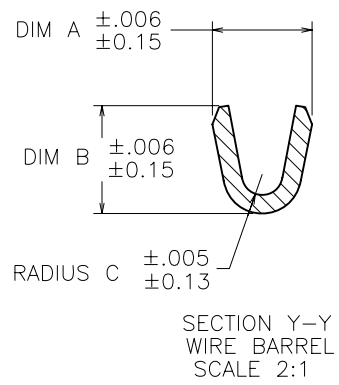
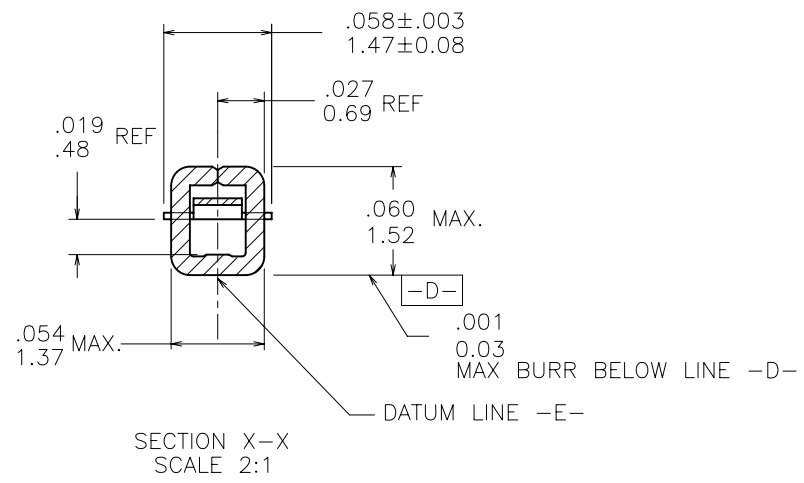
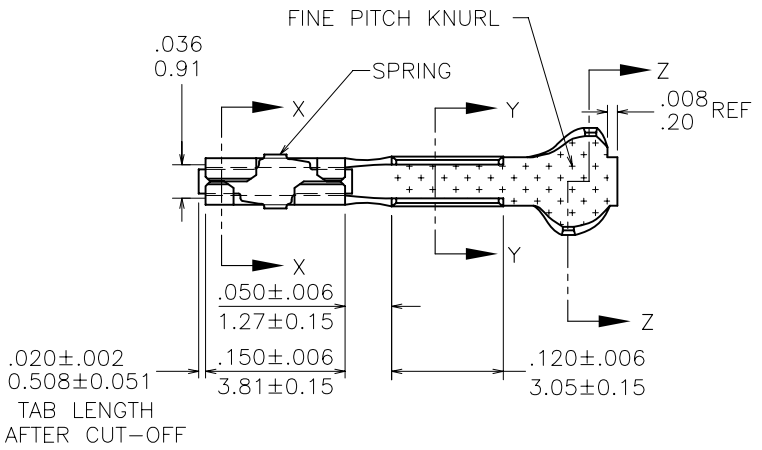

— .003/0.076 E
NOTE 2

mat'l. code				surface	tolerance	projection	product family
SEE TABLE				✓		⊕	PV TERMINALS
ltr	ec'n no	dr	date	tolerances unless otherwise specified		INCH/MM	title
AG	v07-0218	HTB	2007-03-16	angles	.XX±.01/.X±.3		
AH	v08-0113	HTB	2008-03-28	linear	.xxx±.005/.xxx±.13	scale 5:1	MINI PV™ RECEPTACLE CRIMP TO WIRE
AJ	F08-0159	HTB	2008-04-16		.xxxx+0020/.xxx+051		
AK	F08-0189	HTB	2008-06-25	dr	T. BREWBAKER	2006-04-18	dwg no
				engr	T. BREWBAKER	2006-04-18	sheet 1 of 6
AE	v06-0197	HTB	2006-03-03	chr	T. BREWBAKER	2006-04-18	size
AF	v06-0303	HTB	2006-04-18	appd	T. BREWBAKER	2006-04-18	A3
sheet	revision	AK	AK	AK	AK	AK	type Product Customer Drawing
index	sheet	1	2	3	4	5	

PRODUCT NUMBER SEE SHEET 3	AWG	WIRE BARREL			INSULATION BARREL			
	RANGE	DIM A	DIM B	RADIUS C	INSULATION DIAMETER RANGE	DIM D	DIM E	RADIUS F
	18-20	.104/2.64	.104/2.64	.021/.53	.042/1.07-.103/2.62	.139/3.53	.120/3.05	.050/1.27
	22-26	.070/1.78	.070/1.78	.017/.43	.036/.91-.103/2.62	.139/3.53	.120/3.05	.050/1.27
	28-32	.054/1.37	.058/1.47	.011/.28	.028/.71-.054/1.37	.115/2.92	.105/2.67	.040/1.02

NOTES:

1. TERMINAL MATES WITH $.025 \pm .002 / 0.64 \pm 0.05$ SQUARE OR ROUND PIN.
- ② WHEN MEASURED ALONG DATUM -E- WITHIN $.340 / 8.64$ REF DIM.
3. PRODUCT SPECIFICATION: BUS-12-067.
APPLICATION SPECIFICATIONS:
TA-75: TERMINAL DATA FOR USE WITH MINI LATCH HOUSING.
TA-146: TERMINAL DATA FOR CONTACTS NOT USED IN HOUSINGS.
TA-210: TERMINAL DATA FOR CONTACTS USED WITH MINI ROD HOUSINGS.
TA-228: APPLICATIONS USING 20 AWG WIRE.
TA-531: INSTALLING AND REMOVING TERMINALS.
- ④ PRODUCT MEETS EUROPEAN UNION DIRECTIVES AND OTHER COUNTRY REGULATIONS AS DESCRIBED IN GS-22-008.
5. THIS PRODUCT IS NOT INTENDED TO BE EXPOSED TO MANUFACTURING SOLDERING PROCESSES.
- ⑥ THIS PRODUCT HAS 100% TIN PLATING IN THE INTERFACE AND HAS NOT BEEN TESTED FOR WHISKER GROWTH IN ALL INTERCONNECT ENVIRONMENTS.



FCconnect.com

Copyright FCJ

mat'l. code SEE TABLE				surface	tolerance	projection	product family
ltr	ecrn no	dr	date	tolerances unless otherwise specified			PV TERMINALS
AK				angles	linear	INCH/MM	title
						scale 1:1	MINI PV™ RECEPTACLE CRIMP TO WIRE
				dr	T. BREWBAKER	2006-04-18	sheet 2 of 6
				engr	T. BREWBAKER	2006-04-18	size
				chr	T. BREWBAKER	2006-04-18	A3
				appd	T. BREWBAKER	2006-04-18	type
sheet index	revision sheet						Product Customer Drawing

MATERIAL & PLATING		SPRING THICKNESS DIM H±.0005/0.012	AWG RANGE	REELED NOTE 4	LOOSE NOTE 4	PLATING AVAILABILITY							
1/4 HARD BRASS BODY	Be/Cu SPRING					-000	-000LF	-001	-001LF	-002	-002LF		
UNDERPLATING: 50μ"/1.27μ Ni CONTACT AREA: 15μ"/0.38μ Au INSIDE BOX AREA: -000LF Au FLASH -001LF 15μ"/0.38μ Au -002LF 6μ"/0.15μ Au REMAINDER: -000LF Au FLASH -001LF 15μ"/0.38μ Au -002LF Au FLASH	Au FLASH	.0035/0.089	18-20	48241	48250	NO	YES	NO	NO	NO	NO		
			22-26	48242	48251	NO	YES	NO	NO	NO	NO		
			28-32	48243	48252	NO	YES	NO	NO	NO	NO		
		.0048/0.122	18-20	48244	48253	NO	YES	NO	NO	NO	NO		
			22-26	48245	48254	NO	YES	NO	NO	NO	NO		
			28-32	48246	48255	NO	YES	NO	NO	NO	NO		
		.0058/0.147	18-20	94011	94014	NO	NO	NO	NO	NO	NO		OBS.
			22-26	94012	94015	NO	NO	NO	NO	NO	NO		OBS.
			28-32	94013	94016	NO	NO	NO	NO	NO	NO		OBS.
		.0065/0.165	18-20	48247	48256	NO	YES	NO	NO	NO	NO		
			22-26	48248	48257	NO	YES	NO	NO	NO	NO		
			28-32	48249	48258	NO	YES	NO	NO	NO	NO		
UNDERPLATING: 50μ"/1.27μ Ni CONTACT AREA: 30μ"/0.76μ Au INSIDE BOX AREA: -000LF Au FLASH -001LF 30μ"/0.76μ Au -002LF 8μ"/0.2μ Au REMAINDER: -000LF Au FLASH -001LF 30μ"/0.76μ Au -002LF Au FLASH	Au FLASH	.0035/0.089	18-20	48231	48266	NO	YES	NO	NO	NO	NO		
			22-26	48049	48235	NO	YES	NO	NO	NO	NO	YES	
			28-32	48048	48238	NO	YES	NO	NO	NO	NO	YES	
		.0048/0.122	18-20	48047	48232	NO	YES	NO	NO	NO	NO	YES	
			22-26	48046	48234	NO	YES	NO	NO	NO	NO	YES	
			28-32	48045	48237	NO	YES	NO	NO	NO	NO	YES	
		.0058/0.147	18-20	94017	94019	NO	NO	NO	NO	NO	NO	NO	OBS.
			22-26	94018	94020	NO	NO	NO	NO	NO	NO	NO	OBS.
			28-32	93259	94021	NO	NO	NO	NO	NO	NO	NO	OBS.
		.0065/0.165	18-20	48052	48233	NO	YES	NO	NO	NO	NO	YES*	
			22-26	48051	48236	NO	YES	NO	NO	NO	NO	YES	
			28-32	48050	48239	NO	YES	NO	NO	NO	NO	YES	

* LOOSE PIECE NOT AVAILABLE



Copyright FCI

mat'l. code SEE TABLE				surface ✓		tolerance		projection ⊕		product family PV TERMINALS	
ltr	ecrn no	dr	date	tolerances unless otherwise specified				title		MINI PV™ RECEPTACLE CRIMP TO WIRE	
AK				angles	linear	.XX±.01/.X±.3 .XXX±.005/.XX±.13 XXXX±.0020/XXX±.051		INCH/MM		sheet 3 of 6 size	
						scale 1:1		FCI		A3	
				dr	T. BREWBAKER	2006-04-18		dwg no		47212	
				engr	T. BREWBAKER	2006-04-18		type		Product Customer Drawing	
				chr	T. BREWBAKER	2006-04-18					
				appd	T. BREWBAKER	2006-04-18					
sheet index	revision sheet										

MATERIAL & PLATING		SPRING THICKNESS DIM H±.0005/0.012	AWG RANGE	REELED NOTE 4	LOOSE NOTE 4	PLATING AVAILABILITY						
1/4 HARD BRASS BODY	Be/Cu SPRING					-000	-000LF	-001	-001LF	-002	-002LF	
UNDERPLATING: 50µ"/1.27µ Ni CONTACT AREA: 40µ"/1.02µ Au INSIDE BOX AREA: -000LF Au FLASH -001LF 8µ"/0.2µ Au -002LF 8µ"/0.2µ Au REMAINDER: -000LF Au FLASH -001LF 8µ"/0.2µ Au -002LF Au FLASH	Au FLASH	.0035/0.089	18-20	48276	N/A	NO	NO	NO	NO	NO	YES	
			22-26	47457	47743	NO	YES	NO	YES	NO	YES	
			28-32	47456	47742	NO	YES	NO	YES	NO	YES	
		.0048/0.122	18-20	47441	47713	NO	YES	NO	YES	NO	YES	
			22-26	47439	47712	NO	YES	NO	YES	NO	YES	
			28-32	47437	47711	NO	YES	NO	YES	NO	YES	
		.0058/0.147	18-20	94022	94025	NO	NO	NO	NO	NO	NO	OBS.
			22-26	94023	94026	NO	NO	NO	NO	NO	NO	OBS.
			28-32	94024	94027	NO	NO	NO	NO	NO	NO	OBS.
		.0065/0.165	18-20	47566	47746	NO	YES	NO	YES	NO	YES	
			22-26	47565	47745	NO	YES	NO	YES	NO	YES	
			28-32	47564	47744	NO	YES	NO	YES	NO	YES	
DISCONTINUED				48191	48194							
DISCONTINUED				48192	48195							
DISCONTINUED				48193	48196							
UNDERPLATING: 50µ"/1.27µ Ni CONTACT AREA: 75µ"/1.91µ Au INSIDE BOX AREA: -000LF Au FLASH -001LF 75µ"/1.91µ Au -002LF 30µ"/0.76µ Au REMAINDER: -000LF Au FLASH -001LF 75µ"/1.91µ Au -002LF 15µ"/0.38µ Au	Au FLASH	.0035/0.089	18-20	47785	48014	NO	YES	NO	NO	NO	NO	OBS.
			22-26	47784	48015	NO	NO	NO	NO	NO	NO	OBS.
			28-32	47783	48013	NO	NO	NO	NO	NO	NO	OBS.
		.0048/0.122	18-20	47220	47707	NO	NO	NO	NO	NO	NO	OBS.
			22-26	47216	47706	NO	YES	NO	NO	NO	NO	
			28-32	47212	47705	NO	YES	NO	NO	NO	NO	
		.0058/0.147	18-20	94028	94031	NO	NO	NO	NO	NO	NO	OBS.
			22-26	94029	94032	NO	NO	NO	NO	NO	NO	OBS.
			28-32	94030	94033	NO	NO	NO	NO	NO	NO	OBS.



Copyright FCI

mat'l. code SEE TABLE				surface ✓	tolerance	projection ⊕	product family PV TERMINALS
ltr	ecrn no	dr	date	tolerances unless otherwise specified		INCH/MM scale 1:1	title MINI PV™ RECEPTACLE CRIMP TO WIRE
AK				angles	.XX±.01/.X±.3		
				linear	.XXX±.005/.XX±.13 XXXX±.0020/XXX±.051		
				dr	T. BREWBAKER 2006-04-18	FCI	dwg no 47212
				engr	T. BREWBAKER 2006-04-18		sheet 4 of 6
				chr	T. BREWBAKER 2006-04-18		A3
				appd	T. BREWBAKER 2006-04-18		size
sheet index	revision sheet						type Product Customer Drawing

MATERIAL & PLATING		SPRING THICKNESS DIM H±.0005/0.012	AWG RANGE	REELED NOTE 4	LOOSE NOTE 4	PLATING AVAILABILITY								
1/4 HARD BRASS BODY	Be/Cu SPRING					-000	-000LF	-001	-001LF	-002	-002LF			
PRE-PLATED: UNDERPLATING: 50" μ / 1.27 μ Ni OVERPLATING: 100-200 μ / 2.54-5.08 μ 60/40 TIN LEAD "LF NOT AVAILABLE" SEE LEAD-FREE EQUIVALENTS BELOW	Sn PLATED	.0035/0.089	22-26	47445	47747	NO	NO	NO	NO	NO	NO	OBS.		
			28-32	47446	47748	NO	NO	NO	NO	NO	NO	NO	OBS.	
			.0048/0.122	18-20	47221	47716	NO	NO	NO	NO	NO	NO	NO	OBS.
				22-26	47217	47715	NO	NO	NO	NO	NO	NO	NO	OBS.
			.0058/0.147	28-32	47213	47714	NO	NO	NO	NO	NO	NO	NO	OBS.
				18-20	94034	94037	NO	NO	NO	NO	NO	NO	NO	OBS.
		.0065/0.165	22-26	94035	94038	NO	NO	NO	NO	NO	NO	NO	OBS.	
			28-32	94036	94039	NO	NO	NO	NO	NO	NO	NO	OBS.	
			.0035/0.089	18-20	47648	47749	NO	NO	NO	NO	NO	NO	NO	OBS.
				22-26	47649	47750	NO	NO	NO	NO	NO	NO	NO	OBS.
			.0048/0.122	28-32	47650	47751	NO	NO	NO	NO	NO	NO	NO	OBS.
				18-20	47445	47747	NO	YES	NO	NO	NO	NO	NO	OBS.
PRE-PLATED: -000LF 100-160 μ " 2.54-4.06 μ " Sn (LEAD-FREE) NOTE 6	Sn PLATED	.0035/0.089	22-26	47445	47747	NO	YES	NO	NO	NO	NO	OBS.		
			28-32	47446	47748	NO	YES	NO	NO	NO	NO	NO	OBS.	
			.0048/0.122	18-20	47221	47716	NO	YES	NO	NO	NO	NO	NO	OBS.
				22-26	47217	47715	NO	YES	NO	NO	NO	NO	NO	OBS.
			.0058/0.147	28-32	47213	47714	NO	YES	NO	NO	NO	NO	NO	OBS.
				18-20	94034	94037	NO	NO	NO	NO	NO	NO	NO	OBS.
		.0065/0.165	22-26	94035	94038	NO	NO	NO	NO	NO	NO	NO	OBS.	
			28-32	94036	94039	NO	NO	NO	NO	NO	NO	NO	OBS.	
			.0035/0.089	18-20	47648	47749	NO	YES	NO	NO	NO	NO	NO	OBS.
				22-26	47649	47750	NO	YES	NO	NO	NO	NO	NO	OBS.
			.0048/0.122	28-32	47650	47751	NO	YES	NO	NO	NO	NO	NO	OBS.
				18-20	47445	47747	NO	YES	NO	NO	NO	NO	NO	OBS.



FCJconnect.com

Copyright FCJ

mat'l. code SEE TABLE				surface <input checked="" type="checkbox"/>	tolerance	projection 	product family PV TERMINALS
ltr	ecr no	dr	date	tolerances unless otherwise specified		INCH/MM scale 1:1	title MINI PV™ RECEPTACLE CRIMP TO WIRE
AK				angles	.XX±.01/.X±.3		
				linear	.XXX±.005/.XX±.13 XXXX±.0020/.XXX±.051		
				dr	T. BREWBAKER 2006-04-18	FCJ	dwg no 47212 sheet 5 of 6 size A3
				engr	T. BREWBAKER 2006-04-18		
				chr	T. BREWBAKER 2006-04-18		
				appd	T. BREWBAKER 2006-04-18		
sheet index	revision sheet						type Product Customer Drawing

MATERIAL & PLATING		SPRING THICKNESS	AWG	REELED	LOOSE-PIECE	
1/4 HARD BRASS BODY	Be/Cu SPRING	DIM H±.0005/0.012	RANGE	NOTE 4	NOTE 4	
UNDERPLATING: 50u" X 1.27u" Ni CONTACT AREA: 30u" / 0.76u" GXT INSIDE BOX AREA: -600 Au FLASH REMAINDER: -600 Au FLASH	Au FLASH	.0035/0.089	18-20	48231-600	48266-600	OBS.
			22-26	48049-600	48235-600	OBS.
			28-32	48048-600	48238-600	OBS.
		.0048/0.122	18-20	48047-600	48232-600	OBS.
			22-26	48046-600	48234-600	OBS.
			28-32	48045-600	48237-600	OBS.
		.0058/0.147	18-20	94017-600	94019-600	OBS.
			22-26	94018-600	94020-600	OBS.
			28-32	93259-600	94021-600	OBS.
		.0065/0.165	18-20	48052-600	48233-600	OBS.
			22-26	48051-600	48236-600	OBS.
			28-32	48050-600	48239-600	OBS.



FCconnect.com

Copyright FCJ

mat'l. code SEE TABLE				surface	<input checked="" type="checkbox"/> tolerance	projection	product family
ltr	ecn no	dr	date	tolerances unless otherwise specified			PV TERMINALS
AK				angles	linear	INCH/MM	title
					.XX±.01/.X±.3	scale 1:1	MINI PV™ RECEPTACLE CRIMP TO WIRE
					.XXX±.005/.XX±.13		sheet 6 of 6 size
					.XXXX±.0020/.XXX±.051		47212 A3
				dr	T. BREWBAKER	2006-04-18	type
				engr	T. BREWBAKER	2006-04-18	Product Customer Drawing
				chr	T. BREWBAKER	2006-04-18	
				appd	T. BREWBAKER	2006-04-18	
sheet	revision						
index	sheet						